



Truth cam handle locks are designed to provide long and trouble-free service. Two-piece strike design includes a black polyester insert to provide a smooth operation and reduce wear. Inserts are available in various heights to assure tight lock-up of ventilator up to 300 lbs. of forced entry resistance per locking point. The 90° rotation of the handle locks or unlocks the sash. Easily mounts to the face of the window frame.

Truth has also come up with a unique combination of lock and keeper to fill the void in the area of locking handles for basement/hopper windows. By slightly modifying Truth's TrimLine Cam Handle Lock and designing a new high strength steel keeper that can easily be mounted to the window frame, Truth has developed a hardware system that, by simply rotating the handle 90°, easily locks or unlocks these basement/hopper vents.

WARRANTY:

Protected under the terms of the Truth Warranty for Window and Door Manufacturers and Authorized Distributors. Refer to Truth's Terms and Conditions for further details.

MATERIAL: High-pressure die-cast zinc handle, base and strike housing. Strike for use on basement/hopper windows made of high strength steel. #30569 Strike made of painted steel.

FINISH: Electrostatically applied, durable coatings that provide excellent resistance to chipping, scratching and corrosion while maintaining color stability for years in direct sunlight. Please refer to Truth's Color Chart for examples of Truth's most popular finish options. Truth also offers a wide range of decorative "plated" finishes - contact Truth for additional information on availability of these finishes on specific product lines.

ORDERING INFORMATION:

1. Choose cam handle mounting style desired by part number (see drawings for various options). Note: for basement/hopper window applications, order part #25.80 or #25.81 and appropriate steel keepers.
2. Specify finish number desired.
3. Specify left- or right-hand

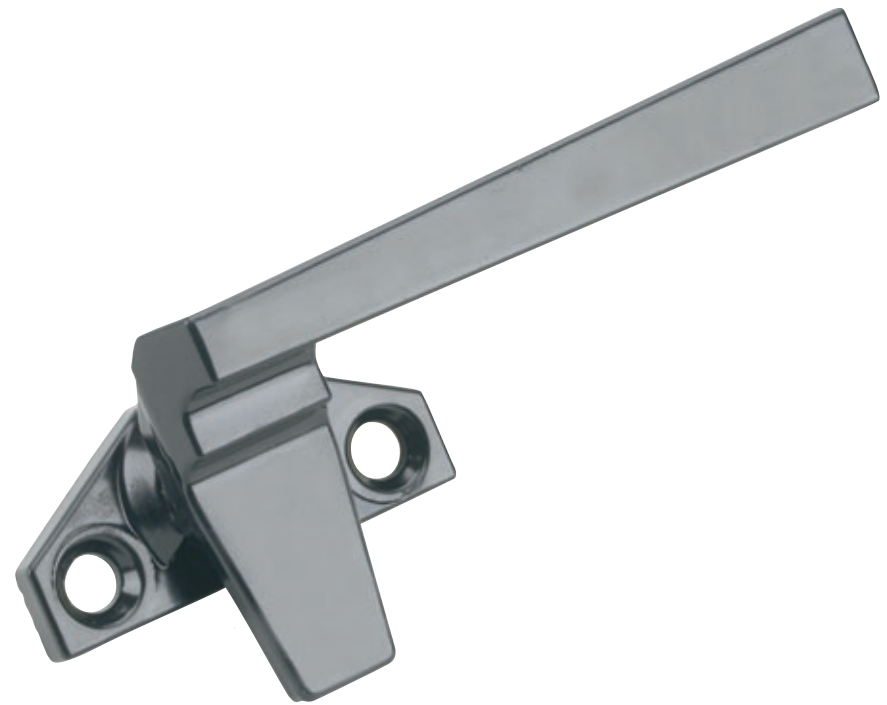

(determined by which direction the handle points, when viewed from the inside on an awning window).

4. Select mounting hardware (sold separately):
 - a. Choose strike and insert part numbers. Make sure strike coincides with handle (offset or in-line). NOTE: #25.29 and #25.31 can be used with a #30569 strike plate allowing use of either left- or right-hand cam handles with the same strike placement.
 - b. Optional —
 - (1) #20408 —Rubber-cork adhesive backed gasket for In-line bases
 - (1) #20556 —Rubber-cork adhesive backed cam handle gasket for Offset bases.

RECOMMENDED SCREWS:

Types of screws required determined by material of profile used. Refer to drawings for complete information on screw type and quantity needed (sold separately). For additional information regarding screw selection - see Truth Tips and refer to Tech Note #11.

TRUTH TIPS:

1. For accurate hardware placement in vinyl or metal applications, pre-drilling of the window profile is recommended.

2. For vinyl window applications, mounting screws should pass through two PVC walls, or one PVC wall and one insert wall. For this reason, it may be necessary to use a longer screw than is recommended.

3. For metal window profiles, Truth recommends machine screws. However, in most applications, sheet metal screws will provide adequate holding power.

INCLUDE TRUTH SPECS ON YOUR NEXT WINDOW PROJECT

Cam handle locks shall be included which will increase both security and weather seal tightness. The locks must hold securely up to 300 lbs. of force per lock for negative air pressure and forced entry resistance.

Window locks shall be of cam handle design and utilize a two-piece strike. The cam handle must be constructed of high pressure zinc alloy die castings. Marring of window surfaces will be eliminated by using a plastic insert mounted in a high pressure zinc die cast strike housing.

Window locks shall be 25 series, TrimLine™ as manufactured by Truth Hardware, Owatonna, MN.

25 TRIMLINE™ CAM HANDLE LOCKS

FIG. 1 APPLICATION OF INLINE AND ANGLE BASE TRIMLINE CAM HANDLES

HARDWARE SHOWN
25.31 CAM HANDLE
20236 STRIKE HOUSING
20233 INSERT

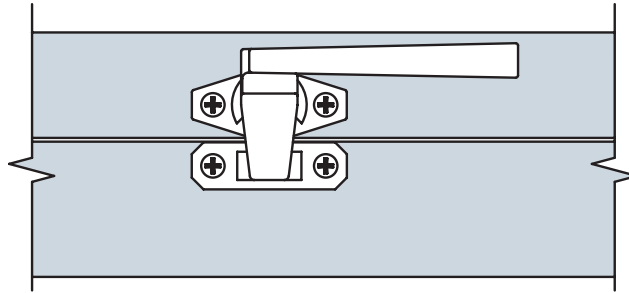

RIGHT HAND SHOWN

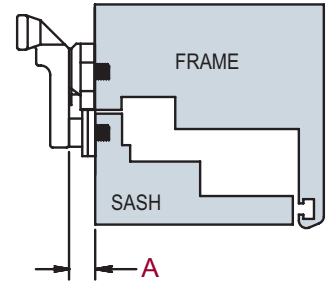

APPLICATION OF ANGLE BASE TRIMLINE CAM HANDLES

HARDWARE SHOWN
25.39 CAM HANDLE
20237 STRIKE HOUSING
20233 INSERT

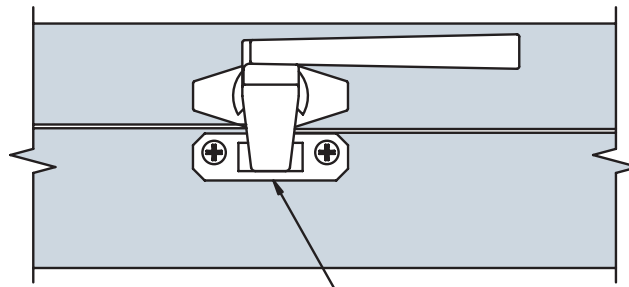

RIGHT HAND SHOWN

STRIKE HOUSING AND INSERT SEE FIG. 8 & 9

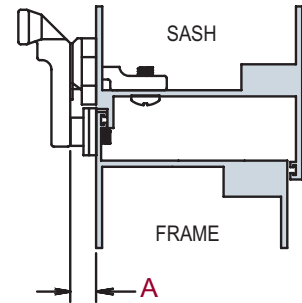
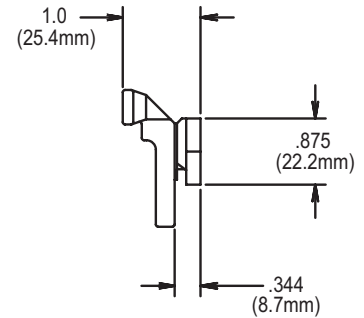
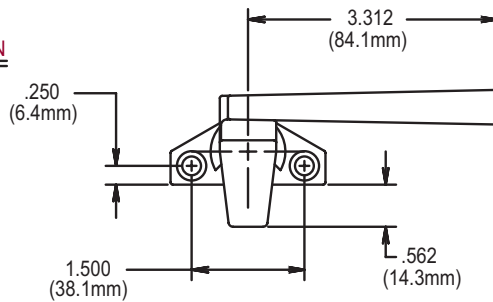

FIG. 2 25.29 CAM HANDLE (Offset Base)

RIGHT HAND SHOWN



RECOMMENDED SCREWS:

METAL: 2 (P/N 19630) #10-24 X .312 PHILLIPS, FLAT HEAD, SST METAL MACHINE SCREWS

PVC/WOOD: 2 - #10 PHILLIPS, FLAT HEAD, SST SCREWS (LENGTH AND THREAD TYPE DETERMINED BY PROFILE)

FIG. 3 25.31 CAM HANDLE (In-Line Base)

RIGHT HAND SHOWN

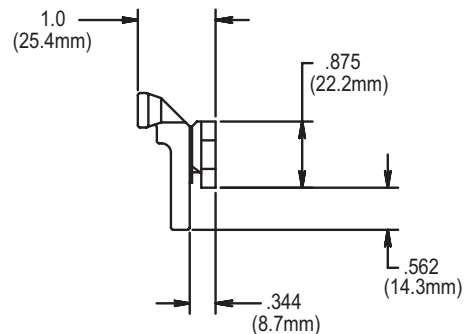
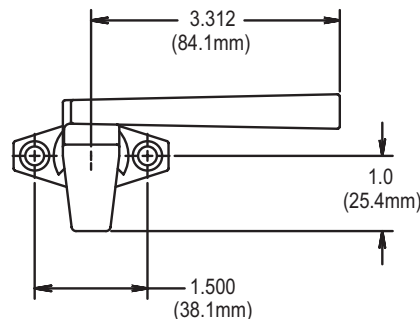

RECOMMENDED SCREWS:

METAL: 2 (P/N 19630) #10-24 X .312 PHILLIPS, FLAT HEAD, SST METAL MACHINE SCREWS

PVC/WOOD: 2 - #10 PHILLIPS, FLAT HEAD, SST SCREWS (LENGTH AND THREAD TYPE DETERMINED BY PROFILE)

FIG. 4 25.39 CAM HANDLE (A-1 angle base)

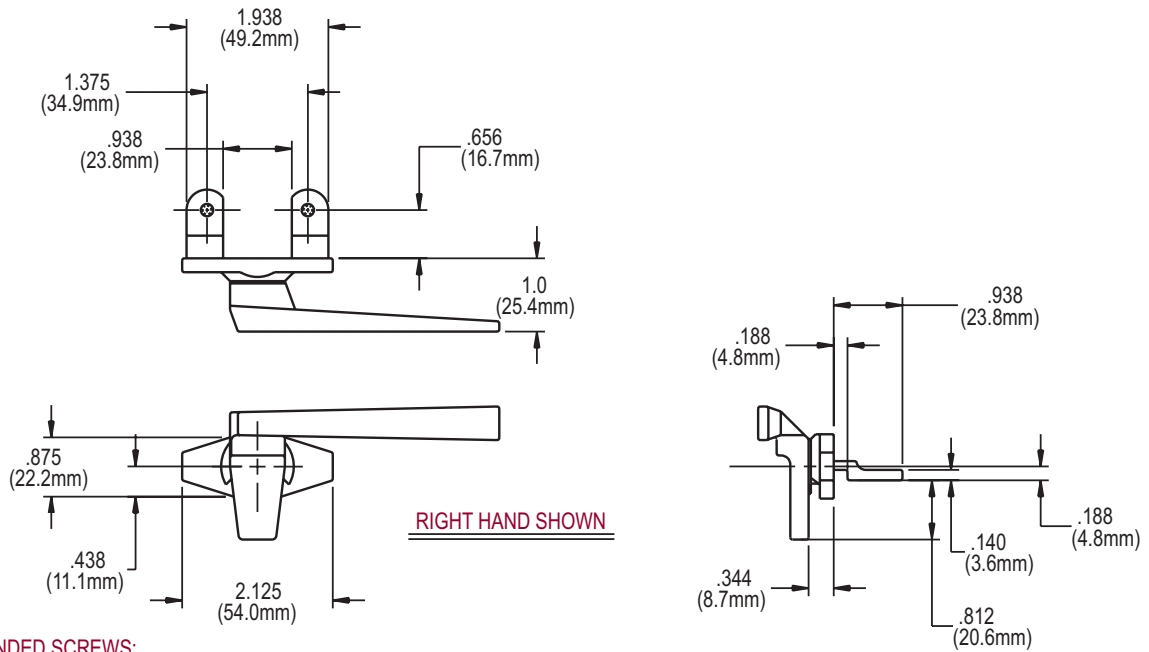

RECOMMENDED SCREWS:

METAL: 2 (P/N 19640) #10-24 X .375 PHILLIPS, PAN HEAD, SST METAL MACHINE SCREWS

PVC/WOOD: 2 - #10-24 PHILLIPS, PAN HEAD, SST METAL MACHINE SCREWS
(LENGTH AND THREAD TYPE DETERMINED BY PROFILE)

FIG. 5 25.76 CAM HANDLE (A-3 angle base)

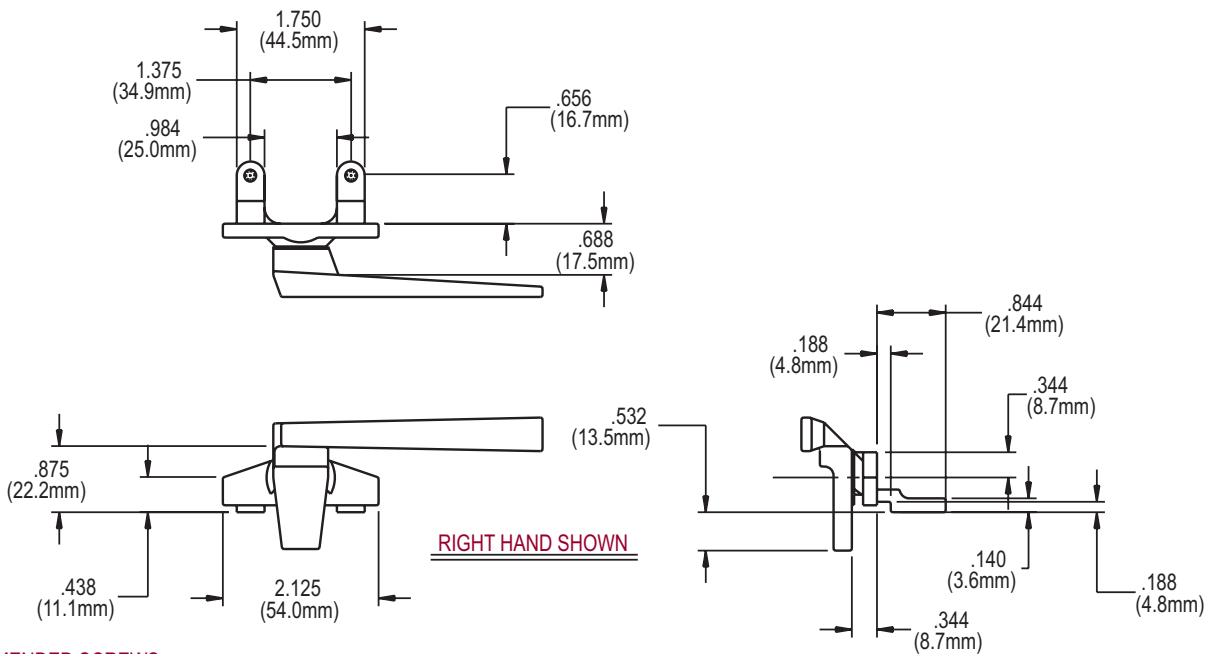

RECOMMENDED SCREWS:

METAL: 2 (P/N 19640) #10-24 X .375 PHILLIPS, PAN HEAD, SST METAL MACHINE SCREWS

PVC/WOOD: 2 - #10-24 PHILLIPS, PAN HEAD, SST METAL MACHINE SCREWS
(LENGTH AND THREAD TYPE DETERMINED BY PROFILE)

25 TRIMLINE™ CAM HANDLE LOCKS

**FIG. 6 25.80 CAM HANDLE FOR HOPPER WINDOWS
25.81 (Inline Base)**

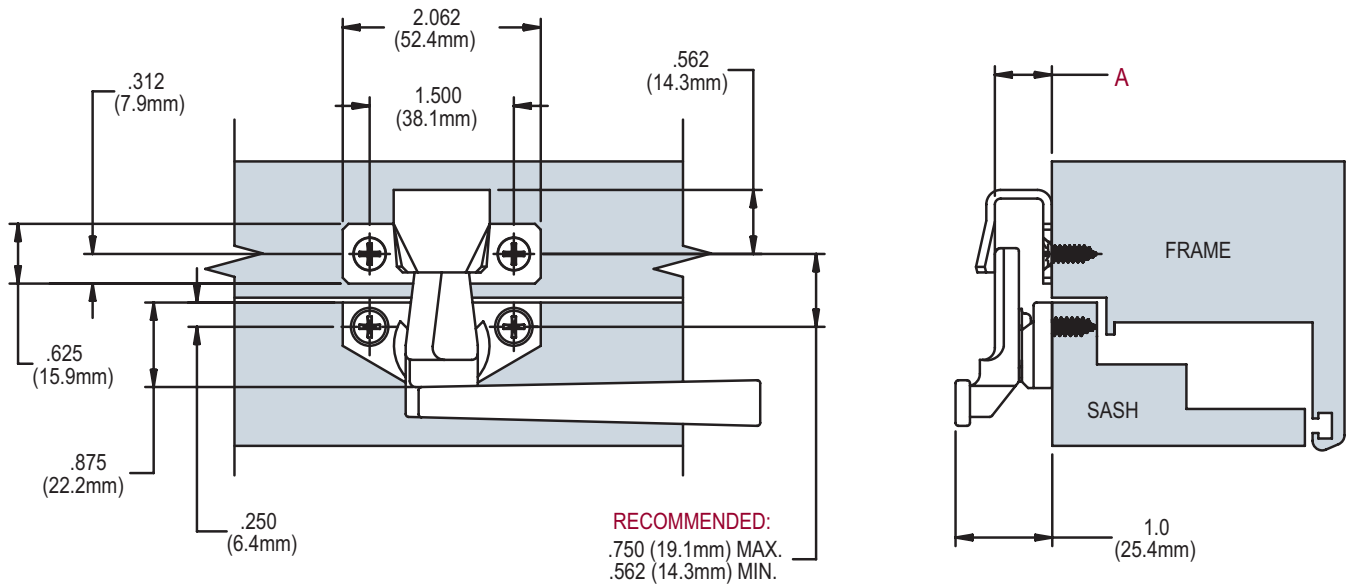

LEFT HAND SHOWN

HARDWARE SHOWN	
25.80	CAM HANDLE
31329	KEEPER

KEEPER	A
31447	.350
31439	.407
31329	.593

RECOMMENDED SCREWS:

WOOD/PVC/METAL: 4 - #10 PHILLIPS, FLAT HEAD, SST SCREWS (LENGTH AND THREAD TYPE DETERMINED BY PROFILE)

FIG. 7 STRIKE PLATE 30569

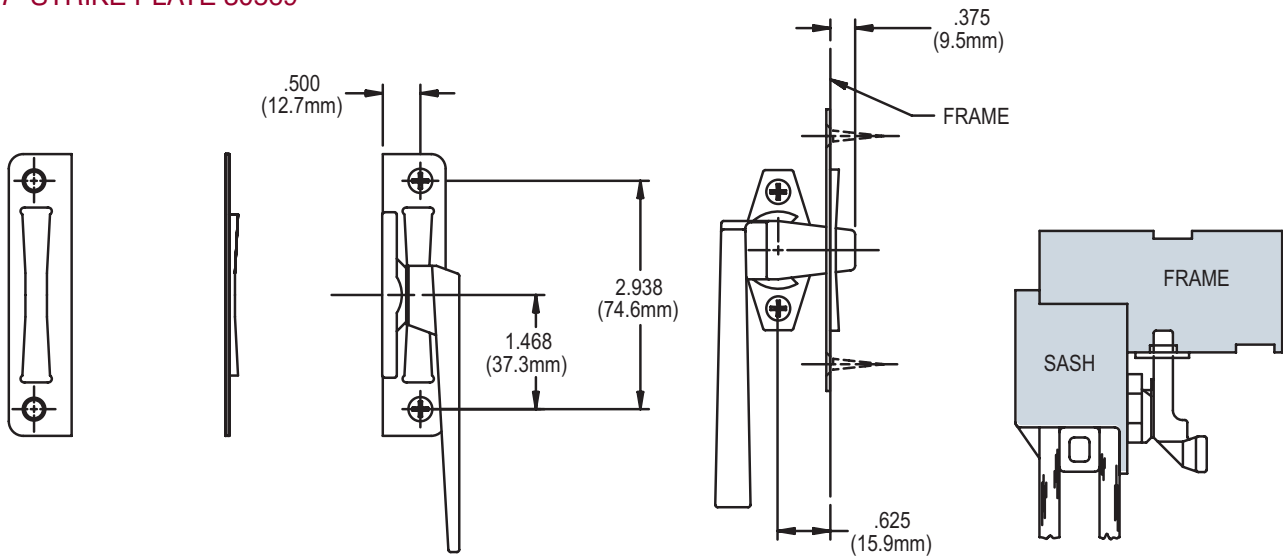

RECOMMENDED SCREWS:

WOOD/PVC/METAL: 2 - #7 PHILLIPS, FLAT HEAD, STEEL SCREWS
(LENGTH AND THREAD TYPE DETERMINED BY PROFILE)

LEFT HAND SHOWN

FIG. 8 IN-LINE STRIKE HOUSING 20236

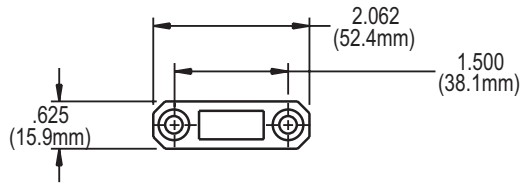

IN-LINE STRIKE HOUSING

A	STRIKE HOUSING NUMBER	INSERT NUMBER
.218 (5.6mm)	20236	20231
.282 (7.1mm)		20232
.344 (8.7mm)		20233

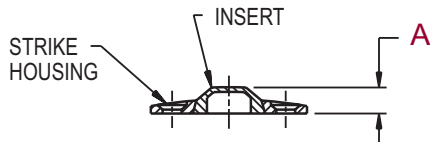

RECOMMENDED SCREWS:

METAL: 2 (P/N 19630) #10-24 X .312 PHILLIPS, FLAT HEAD, SST METAL MACHINE SCREWS

PVC/WOOD: 2 - #10 PHILLIPS, FLAT HEAD, SST SCREWS (LENGTH AND THREAD TYPE DETERMINED BY PROFILE)

FIG. 9 OFFSET STRIKE HOUSING 20237

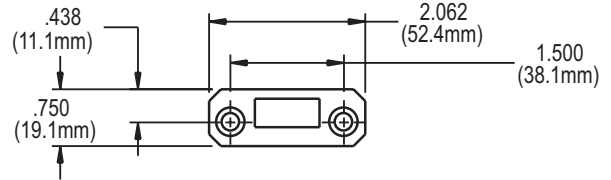

OFFSET STRIKE HOUSING

A	STRIKE HOUSING NUMBER	INSERT NUMBER
.218 (5.6mm)	20237	20231
.282 (7.1mm)		20232
.344 (8.7mm)		20233

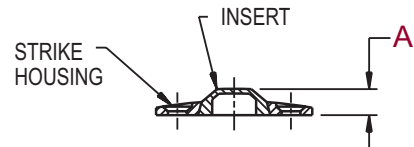

RECOMMENDED SCREWS:

METAL: 2 (P/N 19630) #10-24 X .312 PHILLIPS, FLAT HEAD, SST METAL MACHINE SCREWS

PVC/WOOD: 2 - #10 PHILLIPS, FLAT HEAD, SST SCREWS (LENGTH AND THREAD TYPE DETERMINED BY PROFILE)

FIG. 10 GASKET 20556 (offset base)

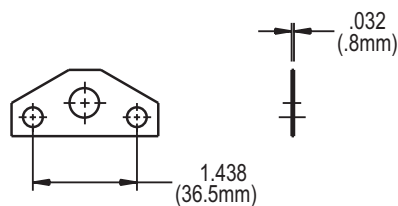
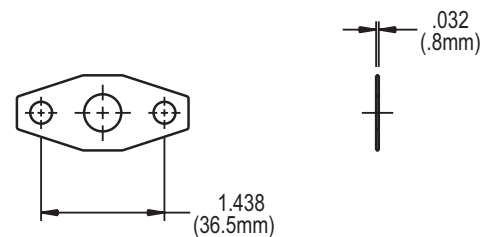

FIG. 11 GASKET 20408 (in-line base)





700 WEST BRIDGE STREET, OWATONNA, MN 55060 ■ 507.451.5620 800.866.7884 ■ TRUTH.COM
