



For use with concealed or exposed hinges, Truth Snubbers prevent bowing of tall casement windows, or wide awning windows and have been found to be useful with double-hung windows in improving the seals of the bottom and top rails in the closed position. Two models feature a PVC insert for use on Aluminum clad units. This PVC insert reduces wear on the finish of the cladding.

Also available is a Concealed Snubber which fits between the sash and frame in a Truth 14 Series Hinge cavity. This hardware eliminates the product from being visible on the exterior of the window

**WARRANTY:**

Protected under the terms of the Truth Warranty for Window and Door Manufacturers and Authorized Distributors. Refer to Truth's Terms and Conditions for further details.

**MATERIAL:** Heavy gauge steel. Models #10325 and #10390 contain a PVC insert.

**FINISH:** #10325 and #10390 models have a phosphate coated, electrostatically painted baked enamel finish which resists chipping and flaking. Standard colors are: 03 Bronze, 22 Clay, 24 Beige, and 32 or 78 White. Optional finishes are available upon request.

**E-GARD® HARDWARE:** Truth's E-Gard® Hardware has a multi-stage coating process that produces a superior physical and aesthetic finish. Plus, it is resistant to a wider range of corrosive materials, including industrial cleaning materials and environmental pollutants. This proprietary process has been tested to be approximately three times better than common zinc plated finishes.

**ORDERING INFORMATION:**

1. Choose Snubber style desired (specify by part number).
2. Specify finish number (when applicable).
3. Select mounting hardware (sold separately).

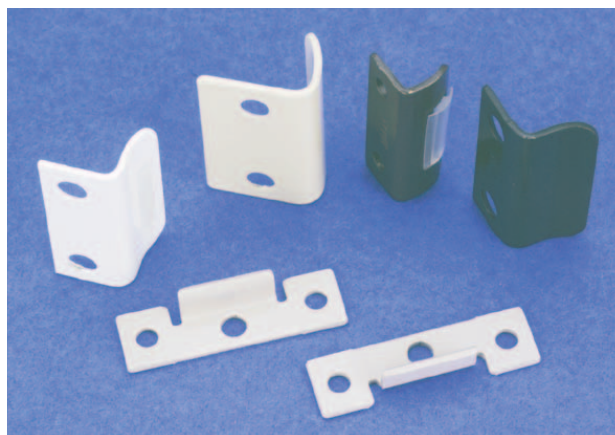

**RECOMMENDED SCREWS:**

Type of screws required determined by material of profile being used. Refer to drawings for complete information on screw type and quantity needed (sold separately).

**TRUTH TIPS:**

1. Truth recommends that a Snubber be used at the center of the hinge side on any casement window which has a tendency to bow outwardly at the center in the closed position.
2. Adding a Snubber may increase the negative air pressure rating of a casement, awning or double hung window.
3. If the sash has a cladded exterior and requires a Snubber, then a Snubber with a PVC insert should be used to prevent marring.
4. For accurate hardware placement in vinyl or metal applications, pre-drilling of the window profile is recommended.
5. For vinyl window applications, mounting screws should pass through two PVC walls, or one PVC wall and one insert wall. For this reason, it may be necessary to use a longer screw than is recommended.
6. When selecting mounting screws for Truth hardware, coating compatibility is one of the most important criteria. For best corrosion resistance the coating on the screws should be the same as the coating on the hardware. See Tech. Note # 11 for further details.

7. For metal window profiles Truth recommends machine screws however, in most applications sheet metal screws will provide adequate holding power.
8. For easy correction of out of square, or racked window installations, the use of Truth Jamb Jack III frame adjusters is recommended. Frame adjustment can improve both weather seal tightness and sash operation over the life of the window.

**INCLUDE TRUTH SPECS ON YOUR NEXT WINDOW PROJECT**

Window sash pressure snubber to be used to increase weatherseal effectiveness by maintaining seal contact on large sash sizes.

Snubbers to be applied to sash and frame sections at points of high deflection to maintain positive seal contact when high negative air pressures are encountered. Constructed of plated steel or stainless steel utilizing a PVC insert where required by profile material.

Snubbers shall be 99 series, as manufactured by Truth Hardware.

FIG. 1 32939.XX CONCEALED SNUBBER AND 31496.XX CONCEALED SNUBBER COMPRESSION

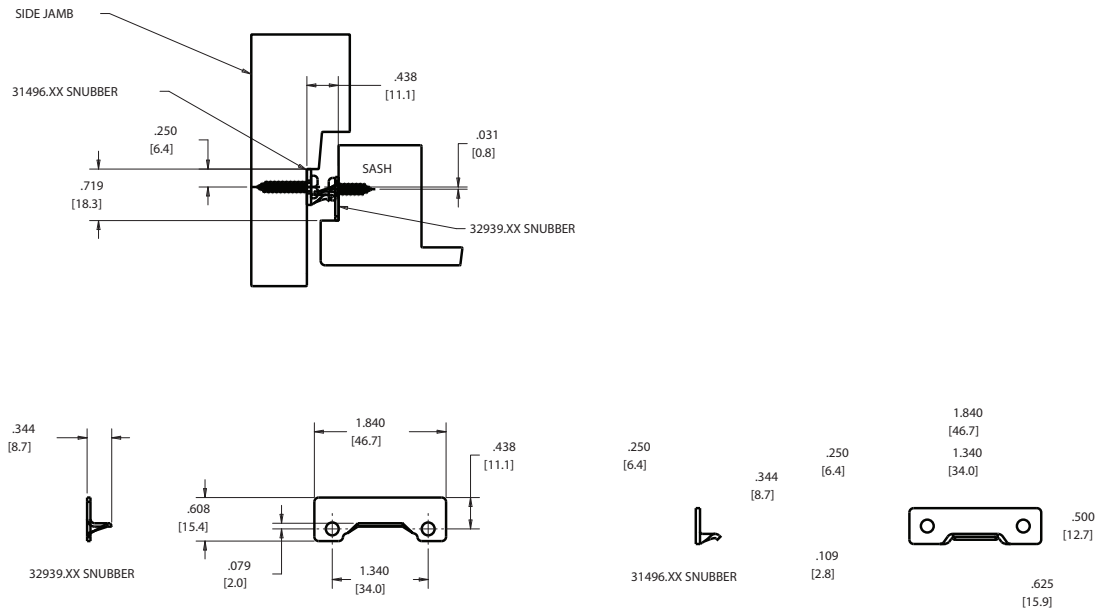

RECOMMENDED SCREWS:  
4 - #8 PHILLIPS PAN HEAD SCREWS  
LENGTH AND THREAD TO BE  
DETERMINED BY PROFILE DESIGN

FIG. 2 32938.XX CONCEALED SNUBBER AND 21642.XX CONCEALED SNUBBER NEGATIVE AIR

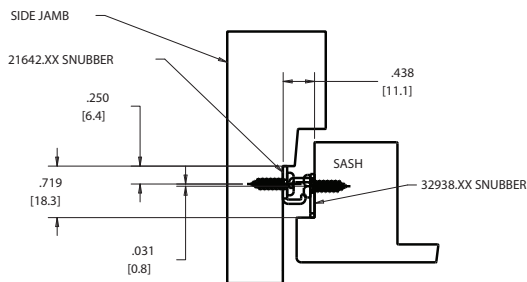

RECOMMENDED SCREWS:  
4 - #8 PHILLIPS PAN HEAD SCREWS  
LENGTH AND THREAD TO BE  
DETERMINED BY PROFILE DESIGN

FIG. 3 22999.XX CONCEALED SNUBBER DIE CAST

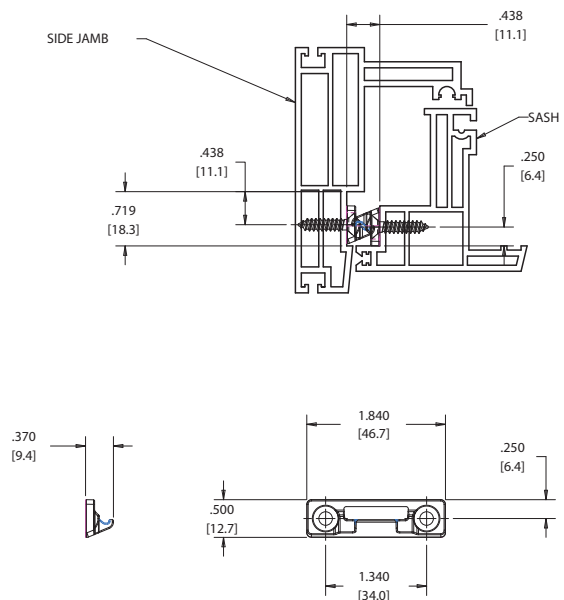

RECOMMENDED SCREWS:  
4 - #8 PHILLIPS FLAT HEAD SCREWS  
LENGTH AND THREAD TO BE  
DETERMINED BY PROFILE DESIGN